

# SPECIFICATIONS

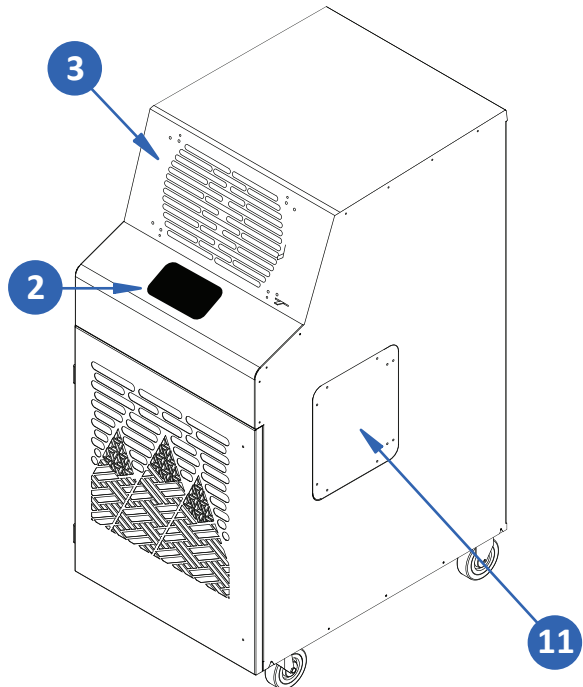

## KWIB1411-2

COOLING CAPACITY	BTU/hr @ 95F at 60% RH	13,800 (1.1-Ton)
COMPRESSOR DATA	Compressor Type	Hermetic Rotary
	Operating Temperatures	60-110 F 50%RH
	Refrigerant	410A
FAN DATA Evaporator	Fan Type (Centrifugal)	Direct Drive
	Air Flow (CFM)	460/3 Speed
	Supply Air Device	Adjustable Vent
	Supply Air Chute Kit (optional)	2 - 5" Dia. x 16" Length
Condenser Water Flow Data	Flow Regulating Valve 1/2"NPT	Automatic
	Inlet Water 85F-95F Exit (GPM)	3
	Inlet Water 75F-95F Exit (GPM)	1.5
	Inlet Water 65F-95F Exit (GPM)	1
	Inlet Water 55F-95F Exit (GPM)	.75
ELECTRICAL DATA	Power Supply (Volts)	115 Single Phase
	Current Consumption (Amps)	8.6
	Power Consumption (Watts)	.9
	Maximum Circuit Breaker (Amps)	20
	Minimum Circuit Ampacity(Amps)	10.225
	Min./Max. Voltage	105-125
	Power Cord Gauge/Length	14AWG/10'
	Plug Configuration	NEMA 5-15
DIMENSIONAL DATA	Width x Depth x Height (Inches)	16" x 22" x 38"
	Weight (Lbs.)	155
	Shipping Weight (Lbs.)	205
	Ceiling Kit Weight (Lbs.)	38
	Shipping Weight w/ Ceiling Kit	283
SAFETY DEVICE DATA	Compressor Overload	Internal
	Fan Motor Overload	Automatic Internal
	Evaporator Freeze Protection	Hot Gas Bypass
	High Pressure Switch	Manual
	Low Pressure Switch	Automatic
	Compressor Short Cycle	Yes
	Automatic Restart	Yes
	Thermostat Type	Microprocessor/Digital
	Condensate Pump Over ow	Yes
Condensate Tank Over ow	Yes	

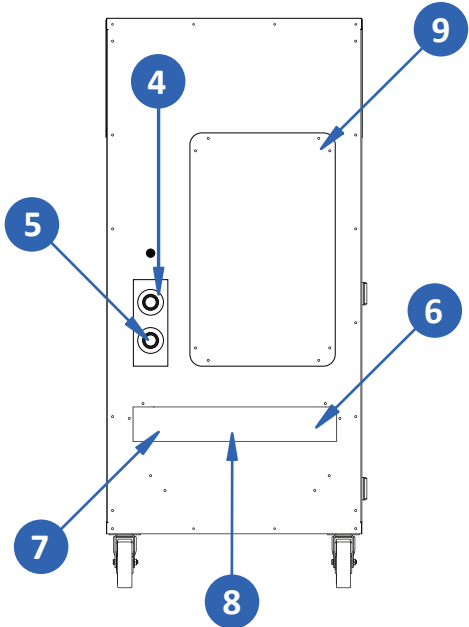
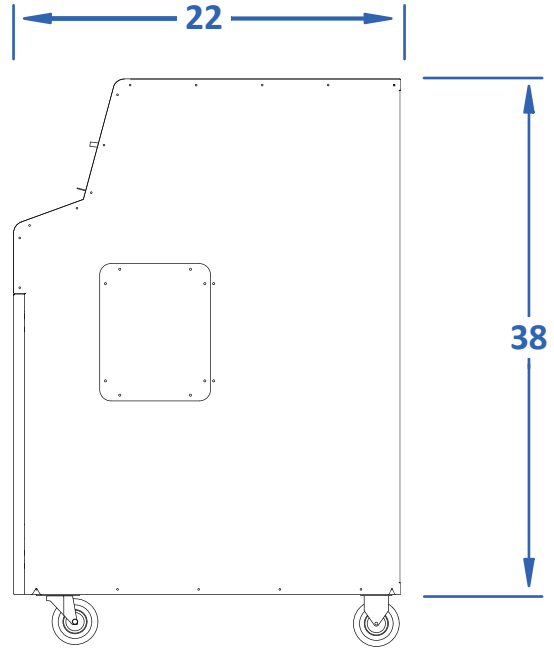
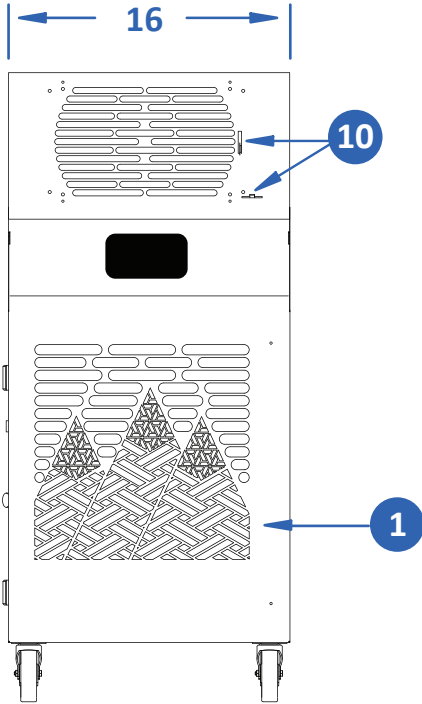

## KWIB1411-2

- |                           |                          |
|---------------------------|--------------------------|
| 1. Cold Air Return        | 6. Cord Storage          |
| 2. Touch Screen Control   | 7. Condensate Nipple     |
| 3. Cold Air Supply        | 8. Condensate Alarm Jack |
| 4. Condenser Water Inlet  | 9. Elec. Access Door     |
| 5. Condenser Water Outlet | 10. Vent Control         |

11. Mechanical Access Door



ETL LISTED CONFORMS TO ANSI/UL1995  
CERTIFIED TO CAN/CSA 22.2 NO 235