

SPECIFICATIONS



KPO5-43

COOLING CAPACITY

| | |
|------------------------|------------------|
| BTU/hr @ 95F at 60% RH | 60,000 (5-Ton) |
| Operating Temperatures | 30 - 110 F 50%RH |

HEATING OPTION

| | |
|-------------------|---------------|
| Heat Strips / BTU | 12kW / 41,600 |
|-------------------|---------------|

COMPRESSOR DATA

| | |
|-----------------|--------|
| Compressor Type | Scroll |
| Refrigerant | 407C |

FAN DATA

EVAPORATOR

| | |
|------------------------------|---|
| Fan Type (Centrifugal) | Direct Drive |
| Air Flow | 2,400 CFM |
| Supply and Return Air Device | 1 - 12" flanges for supply and 1 - 12" for return |
| Maximum Duct length | 50' each for supply and return |

CONDENSER

| | |
|-----------------------------|--------------------------|
| Fan Type (Centrifugal) | Direct Drive |
| Air Flow | 3500 CFM |
| Condenser Exhaust flange | 12" |
| Condenser Duct Max Length | 65" |
| Condenser fan speed control | Variable Frequency Drive |

ELECTRICAL DATA

| | |
|--------------------------|----------------------------------|
| Power Supply | 4600V Three Phase |
| Current Consumption | 14 amps |
| Power Consumption | 11.14 kWh |
| Maximum Circuit Breaker | 20 amps |
| Recommended Breaker Size | 20 amps |
| Minimum Circuit Ampacity | 16.4 amps |
| Min./Max. Voltage | 420-500 |
| Power Quality Control | Internal Phase and Power Monitor |
| Power Connection | Color Coded Male Camlocks |

CONSTRUCTION

| | |
|---------|--|
| Skid | 12 Gauge G90 Galvanized Steel / Epoxy Powdercoat |
| Cabinet | 16 Gauge G90 Galvanized Steel / Epoxy Powdercoat |
| Casters | 6" Heavy Duty Swivel / Locking |

DIMENSIONAL DATA

| | |
|------------------------|---------------------------------|
| Width x Depth x Height | 32" x 48" x 49" with 6" Casters |
| Weight | 700 Lbs. |
| Shipping Weight | 757 Lbs. |

SAFETY DEVICE DATA

| | |
|--------------------------------------|--|
| Compressor Overload | Internal |
| Fan Motor Overload | Automatic Internal |
| Evaporator Freeze Protection | Hot gas bypass with variable fan speed control |
| High Pressure Switch | Manual |
| Low Pressure Switch | Automatic |
| Compressor Short Cycle | Yes |
| Automatic Restart | Yes |
| Thermostat Type | Digital |
| Condensate Pump Overflow | Yes |
| Internal Condensate Pump (high lift) | Yes |

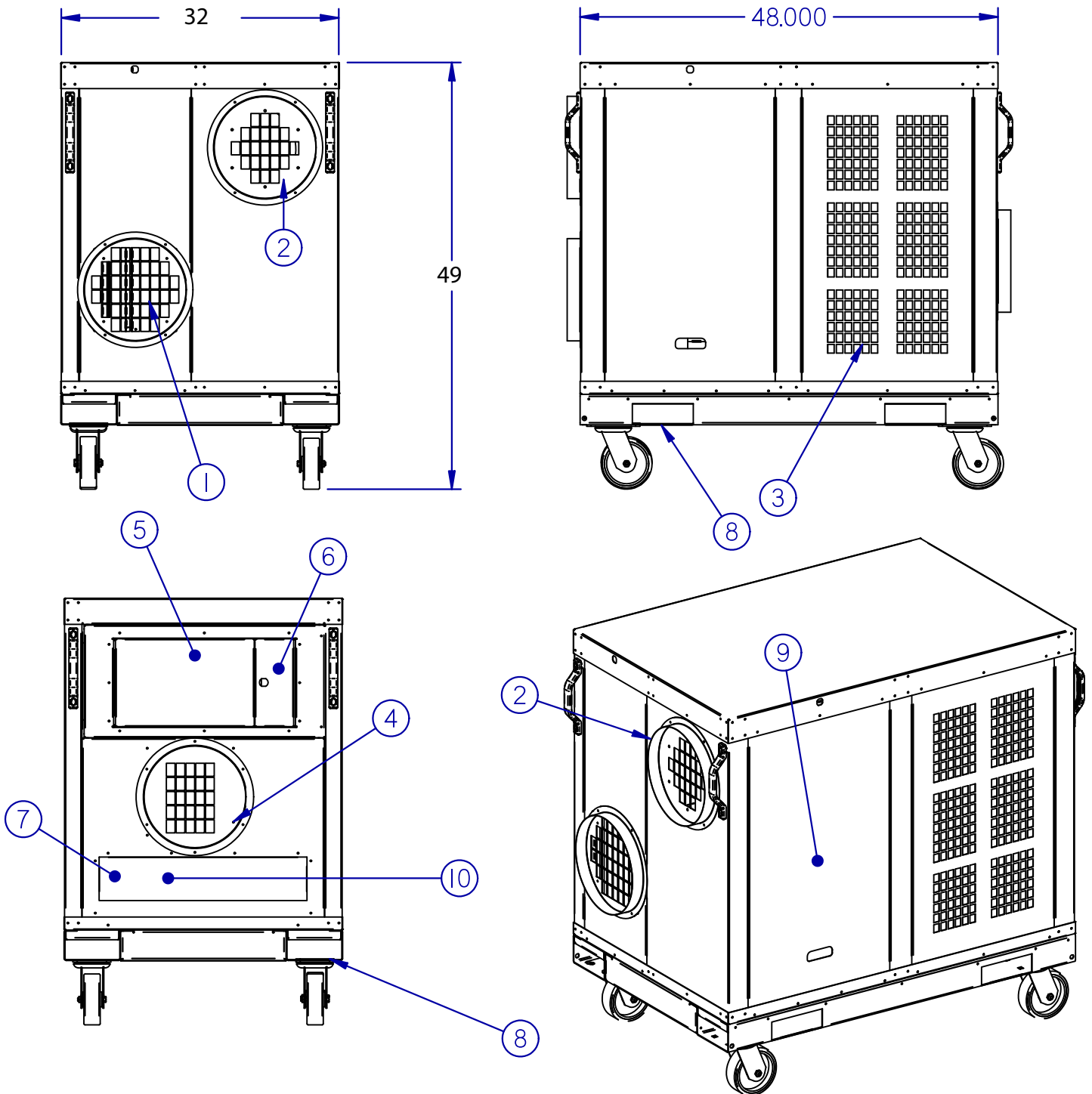

KPO5-43

LEGEND

- | | |
|-------------------------|-------------------------|
| 1. Cold Air Return | 6. Control Panel Access |
| 2. Cold Air Supply | 7. Condensate Nipple |
| 3. Condenser Air Inlet | 8. Fork Pocket |
| 4. Condenser Air Outlet | 9. Access Door |
| 5. Electrical Panel | 10. Power Cord |

