

SPECIFICATIONS



KPO5-23

COOLING CAPACITY	BTU/hr @ 95F at 60% RH	60,000 (5-Ton)
	Operating Temperatures	30-110 F 50%RH
COMPRESSOR DATA	Compressor Type	Hermetic Recip.
	Refrigerant	407C
FAN DATA		
Evaporator	Fan Type (Centrifugal)	Direct Drive
	Air Flow (CFM)	2,400
	Supply and Return Air Device	1-12" flanges for supply duct and 1-12" flange for return duct
	Maximum Duct length	50' total for supply and return.
Condenser	Fan Type (Centrifugal)	Direct Drive
	Air Flow (CFM)	3500
	Condenser Exhaust flange	12"
	Condenser Duct Max. Length	65'
	Condenser fan speed control	Variable Frequency Drive
ELECTRICAL DATA	Power Supply (Volts)	208/230 Single Phase
	Current Consumption (Amps)	26.6/25.1
	Power Consumption (KWatts)	9
	Maximum Circuit Breaker (Amps)	40
	Minimum Circuit Ampacity(Amps)	31.5
	Min./Max. Voltage	195-225/210-250
	Power Cord Gauge/Length	8 AWG/10'
	Plug Configuration	Hard Wired
CONSTRUCTION	Skid	12 Gauge G90 Galvanized Steel with Epoxy Powdercoat
	Cabinet	16 Gauge G90 Galvanized Steel with Epoxy Powdercoat
	Casters	6" Heavy Duty Swivel and Locking
DIMENSIONAL DATA	Width x Depth x Height (Inches)	32" x 48" x 49" with 6" Wheels
	Weight (Lbs.)	670
	Shipping Weight (Lbs.)	735
SAFETY DEVICE DATA	Compressor Overload	Internal
	Fan Motor Overload	Automatic Internal
	Evaporator Freeze Protection	Hot Gas Bypass with variable fan speed control
	High Pressure Switch	Manual
	Low Pressure Switch	Automatic
	Compressor Short Cycle	Yes
	Automatic Restart	Yes
	Thermostat Type	Digital
	Condensate Pump Overflow	Yes
	Internal Condensate Pump (high lift)	Yes



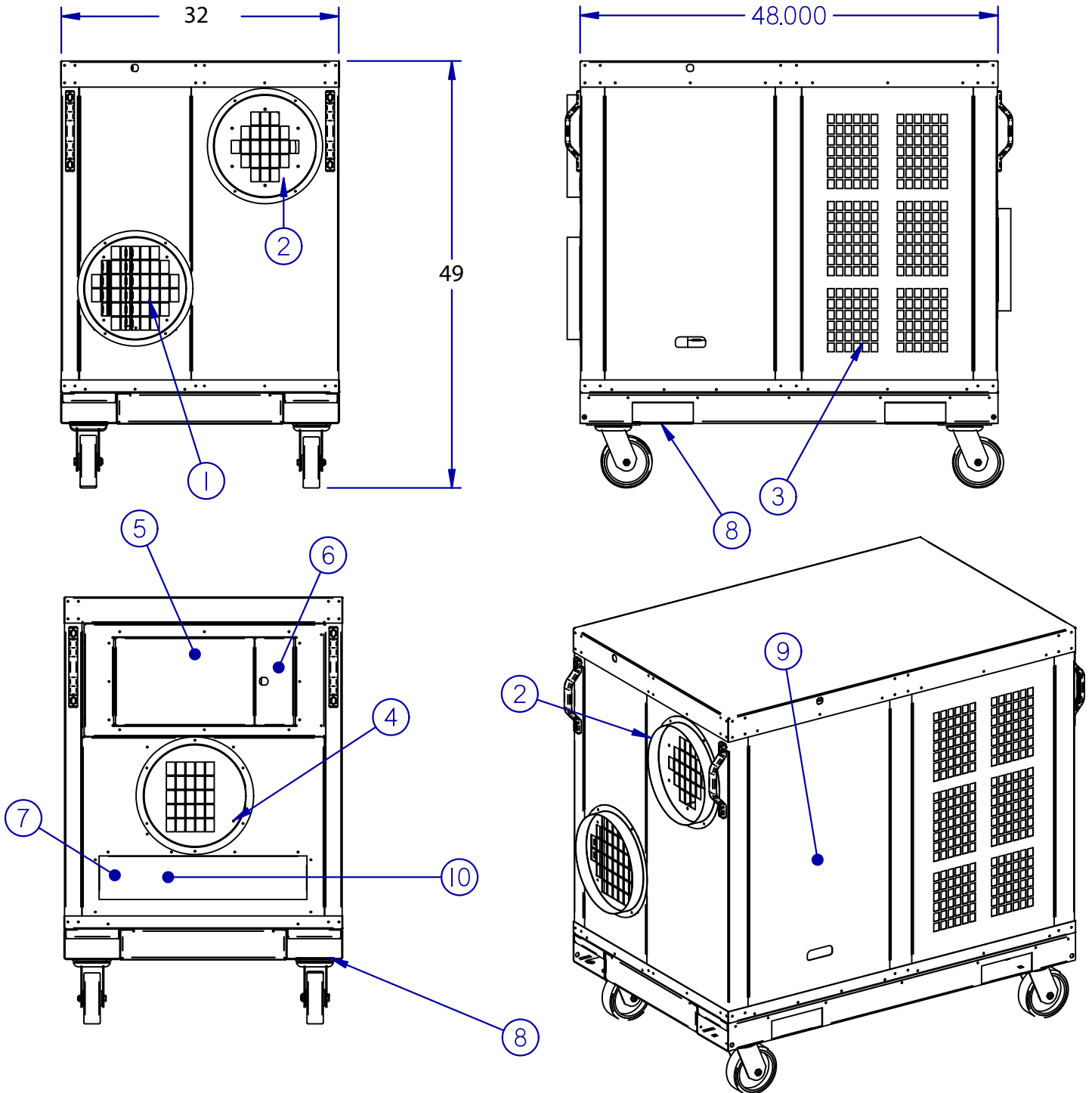

KPO5-23

LEGEND

- | | |
|-------------------------|-------------------------|
| 1. Cold Air Return | 6. Control Panel Access |
| 2. Cold Air Supply | 7. Condensate Nipple |
| 3. Condenser Air Inlet | 8. Fork Pocket |
| 4. Condenser Air Outlet | 9. Access Door |
| 5. Electrical Panel | 10. Power Cord |

