

SPECIFICATIONS

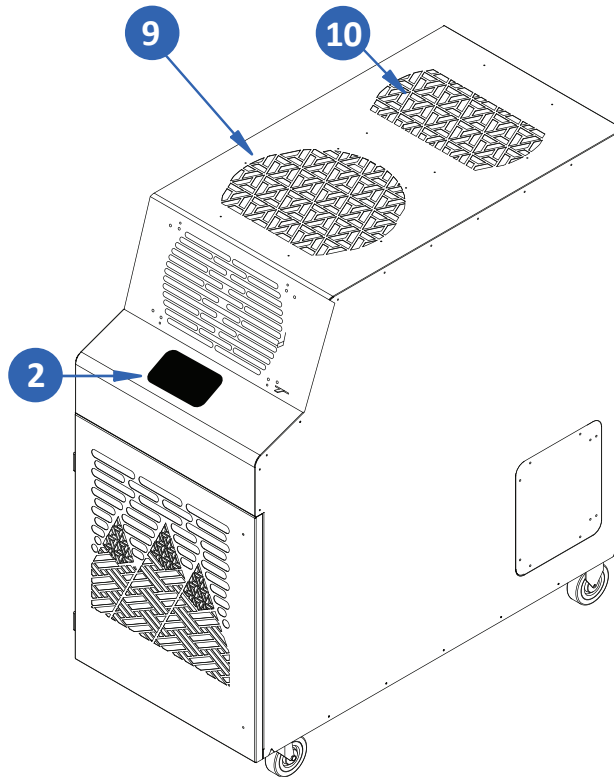

KIB 2421-2

COOLING CAPACITY	BTU/hr @ 95F at 60% RH	23,500 (2-Ton)
COMPRESSOR DATA	Compressor Type	Hermetic Recip.
	Operating Temperatures	60-110 F 50%RH
	Refrigerant	410A
FAN DATA Evaporator	Fan Type (Centrifugal)	Direct Drive
	Air Flow (CFM)	750/3 Speed
	Supply Air Device	Adjustable Vent
	Supply Air Chute Kit (optional)	2 - 6" Dia. x 18" Length
Condenser	I/O Integral Condenser	Balanced Air Flow
	Fan Type (Centrifugal)	Direct Drive
	Air Flow (CFM)	1100
	Condenser Duct Specs (optional)	2 - 14" Dia. x 8' Length
	Condenser Duct Max. Length	50'
ELECTRICAL DATA	Power Supply (Volts)	208/230 Single Phase
	Current Consumption (Amps)	11
	Power Consumption (Watts)	1.4
	Maximum Circuit Breaker (Amps)	20
	Minimum Circuit Ampacity(Amps)	12.525
	Min./Max. Voltage	195-250
	Power Cord Gauge/Length	12AWG/10'
	Plug Configuration	NEMA 6-20
DIMENSIONAL DATA	Width x Depth x Height (Inches)	20" x 41" x 43"
	Weight (Lbs.)	295
	Shipping Weight (Lbs.)	345
	Ceiling Kit Weight (Lbs.)	47
	Shipping Weight w/ Ceiling Kit	392
SAFETY DEVICE DATA	Compressor Overload	Internal
	Fan Motor Overload	Automatic Internal
	Evaporator Freeze Protection	Hot Gas Bypass
	High Pressure Switch	Manual
	Low Pressure Switch	Automatic
	Compressor Short Cycle	Yes
	Automatic Restart	Yes
	Thermostat Type	Microprocessor/Digital
	Condensate Pump Over ow	Yes
	Condensate Tank Over ow	Yes

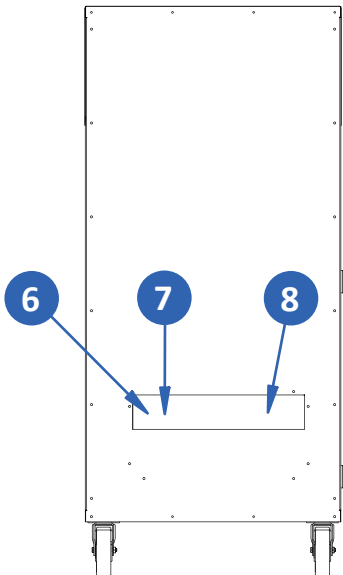
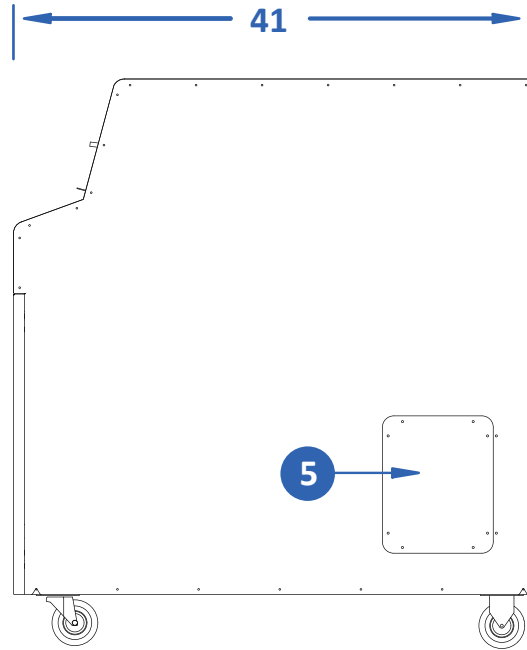
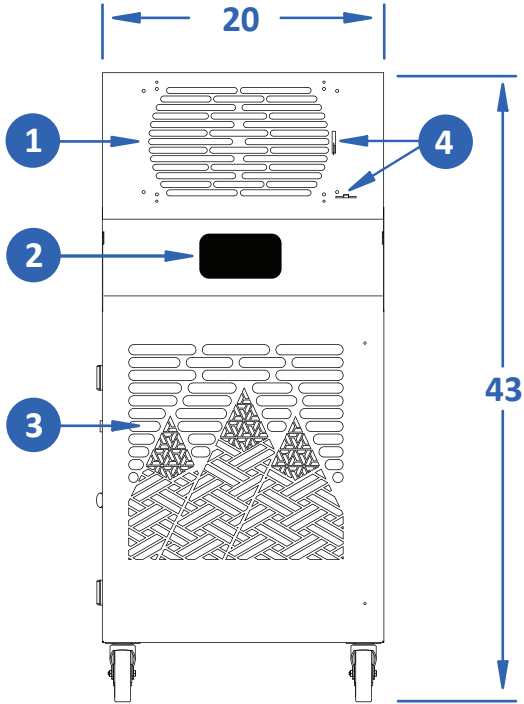

KIB2421-2

- 1. Cold Air Supply
- 2. Kool Pad Control Pad
- 3. Cold Air Return
- 4. Vent Control
- 5. Access Door
- 6. Condensate Nipple
- 7. Condensate Alarm Jack
- 8. Cord Storage
- 9. Condenser Air Inlet
- 10. Condenser Air Outlet

